

EN  
**GEM-OX-GE/U**  
installation guide

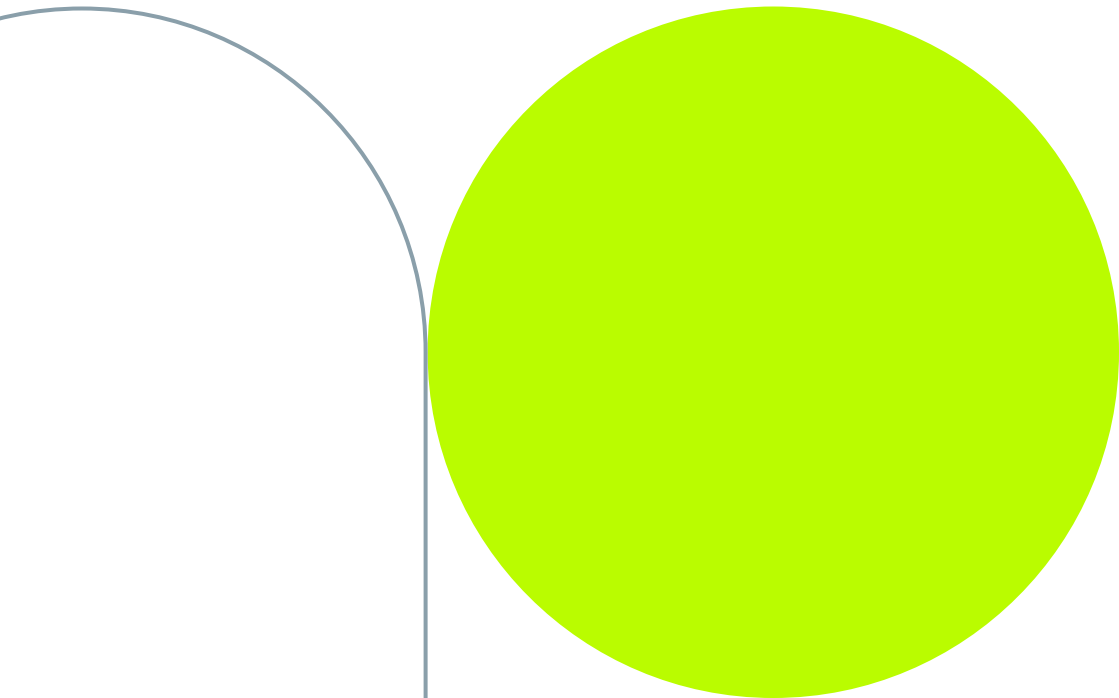

**GemOne®**



# Content

<b>General information</b>	<b>4</b>
<b>Technical specs</b>	<b>5</b>
<b>Dimensions</b>	<b>6</b>
<b>Wiring</b>	<b>7</b>
<b>Wiring guidelines</b>	<b>8</b>
B+	8
ACC (Digital input 1)	8
Digital input 2	9
Digital input 3	9
<b>Schematic</b>	<b>10</b>
<b>Antennas</b>	<b>11</b>
<b>LEDs</b>	<b>12</b>
Navigation LED	12
Network LED	13
<b>Deep sleep mode</b>	<b>14</b>
<b>Input filtering</b>	<b>15</b>
<b>FAQ / Troubleshooting</b>	<b>16</b>
<b>Support</b>	<b>18</b>

# General information

The GemOne tracker is a smart tracker, which combines basic tracking (location and usage based on its inputs) with advanced functionalities (enabling geofences and impact detection, accelerometer...).

The tracker is IP67, which means it can withstand dust and water. Installations should not be protected from dust, rain or splashes of water. See the installation instructions for more information.



# Technical specs

## Power

**Working voltage:** 9-90V DC (max)  
**Battery:** 400 mAh Li-Polymer internal backup battery

## Physical specifications

**Dimensions:** 4.24 × 2.32 × 0.74 mm  
**Weight:** 5.64 ounces  
**Ingress protection:** IP67  
**Operating temp.:** -4°F to 140°F  
**Conformity & Certifications:** CE, FCC, RoHS  
**GSM (data) general:** Internal high gain antenna 4G,SMS / TCP

## Version specifications

### GEM-OX-GE

**LTE FDD:** B1/B3/B7  
B8/B20  
B28A  
**WCDMA:** B1/B8  
**GSM:** B3/B8

### GEM-OX-GU

**LTE FDD:** B2/B4/B5  
B12/B13/B14  
B66/B71  
**WCDMA:** B2/B4/B5

## Connectivity

Bluetooth 4.0 + LE  
2 status LEDs  
3 digital inputs  
2 digital outputs  
1 analog input  
1-wire interface  
12V output  
RS232 (TX and RX)

## GNSS (positioning):

**Receiver:** GPS, GLONASS  
**Antenna:** Internal high gain antenna  
**Accuracy:** 98.4 ft

## Supported peripherals

Built-in accelerometer  
Keypad / RFID reader

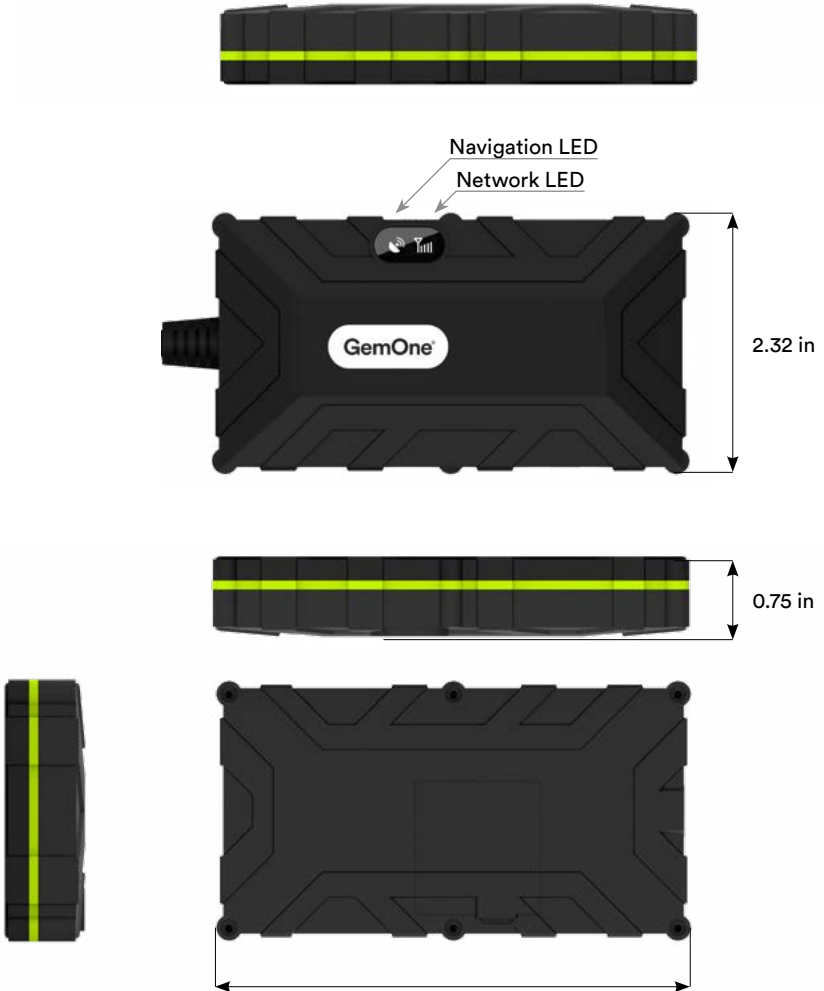

# Dimensions

Our warranty does not cover any damage resulting from unauthorized modification of the product.



# Wiring

The wires on the tracker allow you to measure and monitor the most important points in your machine. Most wires are optional and free to use except for digital input 1 (ACC).

Wire color		Connection	Description
Yellow		B+	Attach to permanent 9-90V DC supply via a 1A fuse (mandatory)
Black		Ground (GND)	Attach to the ground or '-' pole of your machine or battery (mandatory)
Red		Din1 (ACC)	Digital input 1: Ignition input (mandatory) - 0 up to 90V tolerance - Din1 0-8V is logic '0', ACC off - Din1 8-90V is logic '1', ACC on
Grey		Dout1 (relay)	Digital output 1: Access control relay output Open-drain with I <sub>max</sub> = 350mA
Orange		Din2	Digital input 2: Hour counter - 0 up to 90V tolerance - Din2 0-8V is logic '0' - Din2 8-90V is logic '1'
Pink/Black		12V out	12V output I <sub>max</sub> = 120mA
Blue		Din3	Digital input 3: Optional digital input - 0 up to 90V tolerance - Din3 0-8V is logic '0' - Din3 8-90V is logic '1'
Orange/White		RS232_TX1	Do not connect - Reserved for future use
Blue / White		RS232_RX1	Do not connect - Reserved for future use
Brown		Dout2	Digital output 2: Access control feedback output Open-drain with I <sub>max</sub> = 350mA
Purple		1-wire	Access control data
Green		Ain1	Analog input 1 - 0V to 90V

# Wiring guidelines

- **B+**

The tracker must always be powered, preferably directly to the battery of your machine. It must be connected before the emergency switch and key switch to ensure a continuous power supply.

If the tracker is not powered continuously, location of your machine, access control and other features may not work as expected.

- **ACC (Digital input 1)**

Digital input 1 represents the ignition input of our tracker. It is mandatory to connect it to the ignition of your machine. The tracker depends on this input to regulate sleep mode, access control and other advanced features.

The signal must be:

- Low when the machine is off (<8V)
- High when the machine is switched on (>8V) - before the engine is running
- High while the engine is running
- Low when the machine is turned off



- **Digital input 2**

Digital input 2 represents the hour counter, but - unlike digital input 1 - it is not mandatory to connect it to your machine.

You are free to connect DIN2 to any point in your machine which monitors the usage:

- Physical hour counter with on/off input
- Signal indicating when the engine is on/off
- Pneumatic or hydraulic pumps on/off
- Seat switch
- Foot pedal

If none of the above suggestions are available on your machine, you can opt to base the hours calculation on the ignition input in our cloud platform.

- **Digital input 3**

Digital input 3 is optional and can be used to capture additional information from your machine.

Some machines place the main breaker or the emergency switch between the '-' pole of the battery and the chassis. This will cause invalid signals on all inputs. To prevent this from happening, digital input 3 can be wired to the chassis. More information can be found in section Input filtering.

# Schematic

You can find the wiring scheme of the basic installation below. With this installation, the ignition and hour meter will be captured. Digital input 3 can be used to capture additional information from your machine.

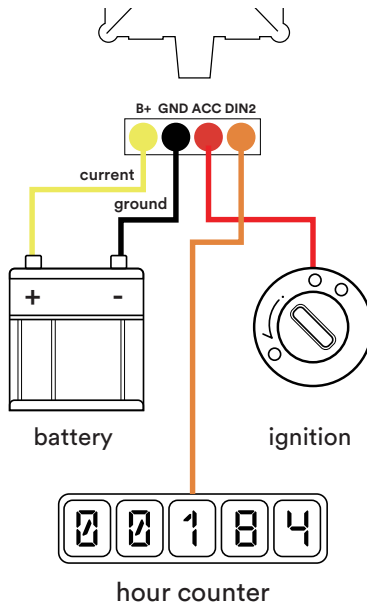

B+, GND and ACC (DIN1) are mandatory for every installation.

You are free to connect DIN2 to any point in your machine which monitors the usage:

- Physical hour counter with on/off input
- Signal indicating when the engine is on/off
- Pneumatic or hydraulic pumps on/off
- Seat switch
- Foot pedal

# Antennas

The GemOne tracker has an internal GNSS (GPS) and GSM antenna.

For the antennas to work correctly, the tracker should be mounted with the sticker view to the open sky (metal free) with not less than  $\frac{3}{4}$  of metal free area as shown in figure below.

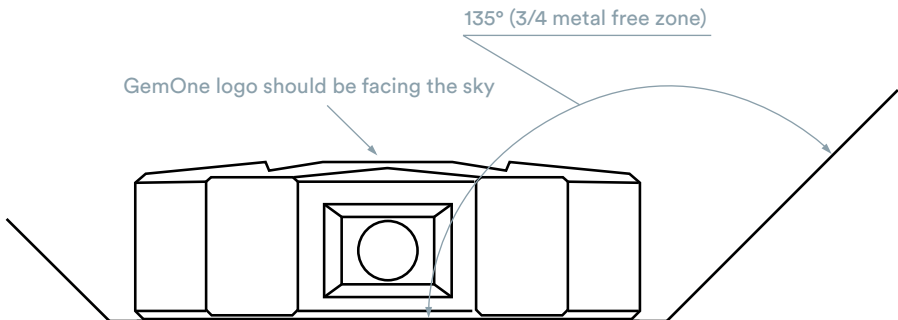

It is not important in which direction the tracker is installed. The most important instruction is that the GSM and GNSS antenna have a good open view.

# LEDs

The tracker has two LEDs: a navigation LED and a network LED. The navigation LED has a blue color, the status LED has a green color.

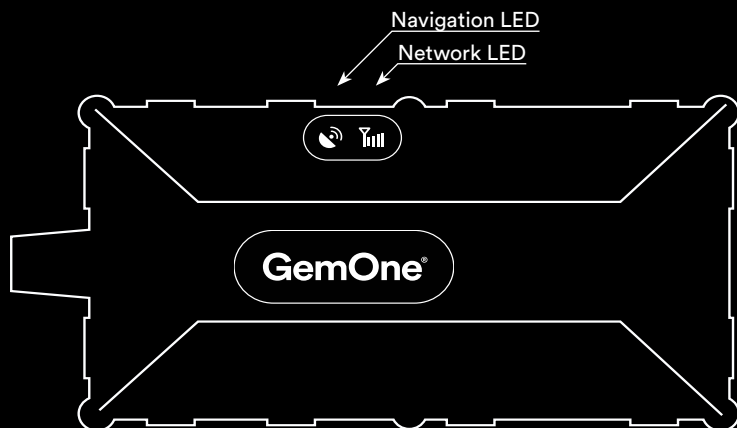

## Navigation LED

Behaviour	Meaning	OK?
Blinking quickly	GPS signal is not received	No
Blinking slowly ( 1 second on, 4 seconds off)	Normal mode, GPS is working	Yes
Off (sleep mode)	GPS is in power-saving mode	Yes
Off (normal mode)	GPS faulty	No

If the Navigate LED is off, check the status LED (see next page) to make a distinction between Deep sleep mode and GPS antenna short circuited. The latter won't happen often.

## **Network LED**

<b>Behaviour</b>	<b>Meaning</b>	<b>OK?</b>
Blinking quickly	Modem activity	Yes
Blinking slowly (shortly on, 2 seconds off)	Searching for network	Yes (temporarily while connecting)
Blinking slowly (shortly on, ~5 seconds off)	Tracker in sleep mode	Yes
Blinking slowly (shortly off, 2 seconds on)	Idle - no network activity	Yes
Off	Tracker not powered or faulty	No

# Deep sleep mode

The tracker is configured to use deep sleep mode to preserve the vehicle's battery charge. If no movement is detected and the ignition is off (digital input 1), after 10 minutes it will go into deep sleep mode. This means that the GPS module is switched off and only the ignition (digital input 1) is monitored for changes. The tracker also sends a message every hour if no activity is detected.

If the tracker is in deep sleep, we can still reach it via SMS (e.g. to wake up.).

Deep sleep mode is switched off when the internal accelerometer detects movement or when the ignition is switched on.

# Input filtering

Some machines place the main breaker or the emergency switch between the '-' pole of the battery and the chassis. In that case, the machine is always connected to the '+' pole of the battery. This could cause a voltage on the inputs of our tracker, which will be interpreted as activity (eg. ignition on, hour counter running ...)

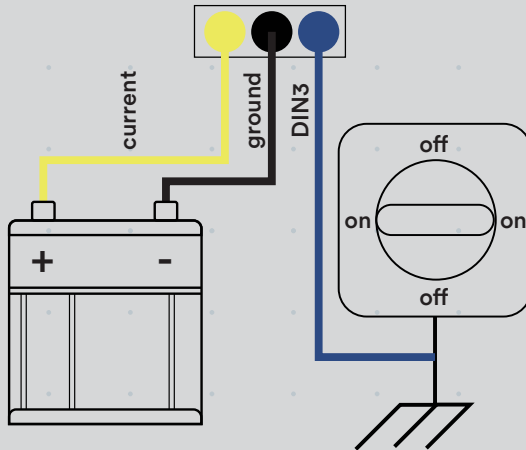

To detect this situation, the tracker needs an additional connection (DIN3 - blue) to the chassis. This input can detect invalid signals and will allow the cloud platform to filter other invalid inputs as well. Make sure you enable input filtering in the cloud platform on digital input 3 when this feature is needed.

# FAQ / Troubleshooting

- **None of the LEDs turn on.**

- Verify if the tracker has power between B+ (yellow) and GND (black). The tracker needs a voltage between 9-90V
- Verify if the 1A fuse is still intact
- Make sure that the ignition input (ACC) is wired correctly
- Check if DC-DC converters are used and if the ground is isolated

- **The tracker sends data but I can't see the location of the vehicle.**

Verify if the installation was done according to the guidelines. The GemOne logo should face the open sky, without metal obstructions. See 'Antennas' section for more information.

The GPS signal isn't always available inside so location tracking may not work indoors.

- **Ignition or hour counter input stays high - even if the machine is not running.**

Check if the ignition is actually used by the operators. In a lot of cases, the emergency switch is used instead of the ignition switch. On some machines, this disables the machine but keeps the ignition signal high. The installation must match the actual usage of the machine. If the emergency switch is used instead of the ignition switch, then it might be better to use another point in the machine. Please consult your machine's technical documentation for more information.

The same applies to all other inputs including digital input 2 (hour counter).



- **My machine has multiple control panels - which ignition signal do I use?**

Some machines have multiple control panels, each with its own key switch and/or emergency stops (eg. one on the platform and another on the ground control panel). In that case, you have to make sure that the ignition digital input of our tracker measures both signals. Some machines have a combined signal available, please consult your schematic and manual.

If no combined signal is available in the machine, one can be constructed using two diodes:

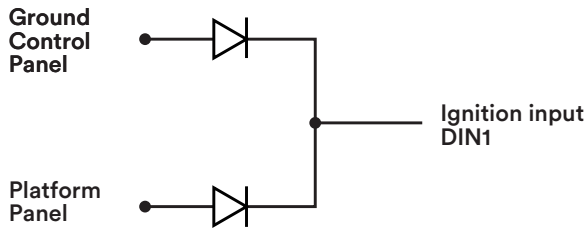

Make sure you use suitable diodes for your application (maximum voltage, ...). Commonly used diode types are: 1N4005 or 1N4007

# Support

In case of issues, questions or feedback, feel free to contact our support team.

 +1-844-275-2801

 [techservice@gemone.com](mailto:techservice@gemone.com)

## Save time with our connectors

Request connectors for your machines to save time while installing this tracker. GemOne offers a multitude of different connectors. Get in contact with your account manager for an offer.



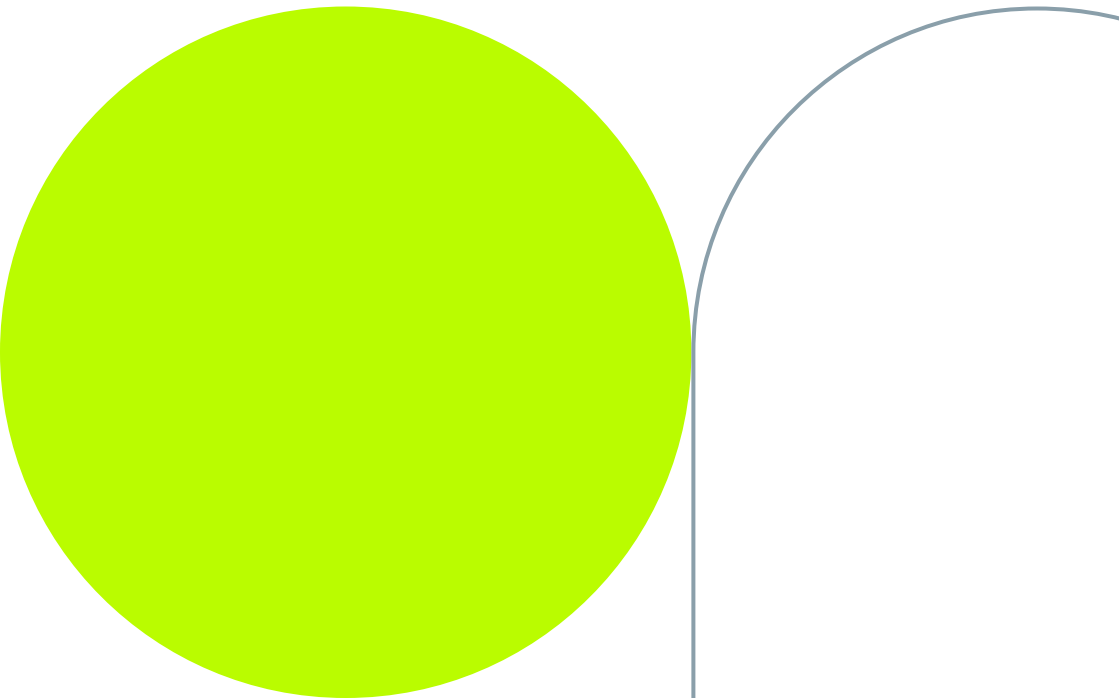

## Lets get connected:

- 📷 [instagram.com/gemoneofficial](https://www.instagram.com/gemoneofficial)
- 📘 [facebook.com/gemone.telematics](https://www.facebook.com/gemone.telematics)
- 🌐 [linkedin.com/company/gemone](https://www.linkedin.com/company/gemone)
- 🐦 [twitter.com/GemOne\\_](https://twitter.com/GemOne_)
- ✉️ [support\\_emea@gemone.com](mailto:support_emea@gemone.com)

**[www.gemone.com](http://www.gemone.com)**



©2021 - GemOne NV, Spinnerijstraat 99/23, BE-8500 KORTRIJK. All rights reserved. No part of this publication may be reproduced or communicated in any form or by any means, electronic or mechanical, including copying, recording or use in an information storage or retrieval system, without prior and explicit permission of GemOne NV. Photographs and illustrations are included for reference purposes only. GemOne is a registered brand.